

## Service Requirements

### General

Contact Idaho Power before beginning work on any new service.

All meter installations must meet current electrical code requirements and display the proper electrical permit.

To help prevent damage, always call **Dig-Line** for locations at least **2 business days** before digging, excavating, or driving a ground rod.

Dial **811** (Nationwide)

### Service Voltages

**Single Phase (1-Ø)** 120/240 volts  
240/480 volts  
120/208 volts (“network”)

**NOTE.** Use the correct meter base for 1-Ø, 120/208 volt “Network” applications.

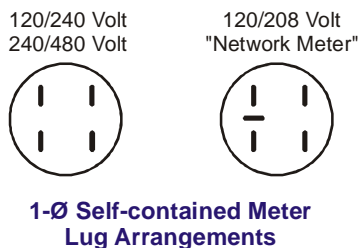

### Meter Location

The meter and any associated equipment must be located so that the installation and any future maintenance can be performed without undue inconvenience to the customer or Idaho Power. Locate residential as shown.

The meter must be located in a reasonably protected area so that the risk of inadvertent damage is minimized.

Placing the meter in front of the fence keeps Idaho Power out of the back yard.

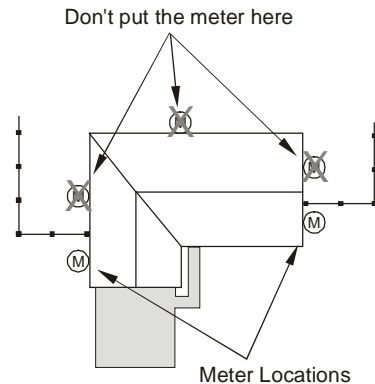

The meter base, conduit, and any CT enclosure must be adequately supported on the outside of an outside structure wall so that it will be readily accessible to Idaho Power. **Do not cover or enclose the meter.**

### Meter Poles

All poles for mounting metering equipment are provided, installed and owned by the Customer. They must be tall enough to provide adequate clearance above the finished grade or obstacles for the service conductor and drip loop and be in good “climbable” condition.

Each pole must have a minimum setting depth of **10% of the length of the pole plus 2'-6"**. Additional bracing must be installed if the tension of the service conductor will cause the pole to lean. A minimum Class 6 pole is required for permanent service.

See *Definitions* for Class 6 pole.

### Meter Base Guidelines

Refer to the *Meter Base Identification Guidelines* located on [www.idahopower.com](http://www.idahopower.com).

# Requirements for Single-Phase (1-Ø) Overhead Electric Service

## Meter Height

**Permanent meters** must be 5'-6" (+/- 6") above the finished grade or other accessible surface such as a deck or stairs, except as noted below.

- ◆ Multiple meter bases must be installed so that the lowest meter is at least 4'-0" above the finished grade.

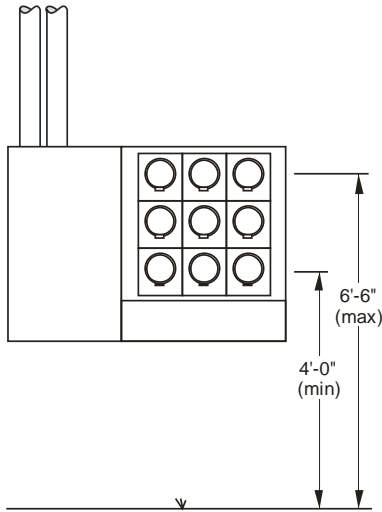

## Multiple Meters

Each meter base or service disconnect that is part of an installation with more than one meter is required to be plainly and permanently marked with numbers or letters that corresponds to the address, suite, office, or room it serves.

## Meter Rooms for Multiple Meters

Multiple meter installations may be located in a meter room provided that all of the following criteria are met:

1. A plan for the meter room must be submitted to Idaho Power for approval before any wiring is done.
2. The meter room must be accessible to Idaho Power through an exterior metal door with a lock box. The door must be permanently labeled with the words "Electrical Room".

3. The meter room may only be used for electrical equipment and communication equipment that does not interfere with the electrical equipment. No storage of any kind will be allowed.
4. Lighting, drainage and health issues are the responsibility of the customer.

## Special Meter Base Requirements

**480 volt meter bases.** EUSERC-approved safety socket meter bases with factory installed test bypass facilities are required for 480 volt self-contained meters to provide a means to de-energize and isolate the meter. These meter bases must have an interlocking device, a screw-type meter ring, and be capable of being sealed by Idaho Power.

**1-Ø, 400 amp meter bases.** These meter bases must not have a link bypass or a lever bypass. Locking jaws are acceptable.

## Clearances

**Electric and Gas Meters.** The electric meter (or any electrical equipment) and a gas meter must be separated by at least 36" measured in any direction, except that the horizontal separation shall not be less than 18".

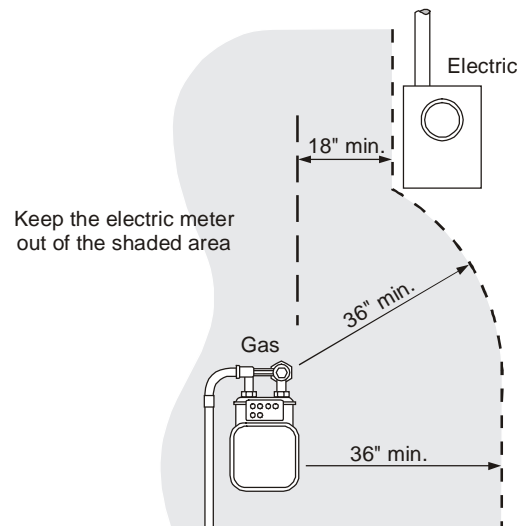

# Requirements for Single-Phase (1-Ø) Overhead Electric Service

**Propane Tanks.** Any regulator, pressure relief valve, or fill connection associated with a propane tank or its delivery system must be at least 10' away from any source of ignition, which includes the electric meter, air conditioning unit, etc. Keep the service cable and conduit at least 3' away from the tank.

**NOTE.** Propane tanks that are used for dispensing (filling other tanks) must be at least 20' from any source of ignition.

**Working Space.** Keep the 36" x 36" area in front of the meter clear of any equipment, landscaping or other obstacles that could interfere with access to the meter.

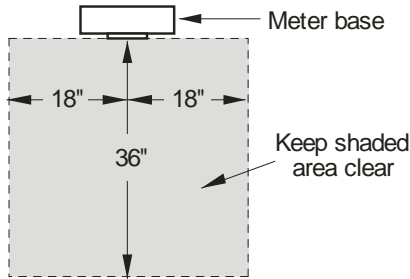

## Caution: Portable Generators

Do not connect a portable generator to a building's electrical wiring unless a transfer switch has been installed per NEC 702. The transfer switch prevents the generator from feeding back into the Idaho Power electrical system, exposing workers to unforeseeable hazards. The generator can also be damaged if the electrical system becomes energized while the generator is operating.

## Heights for Overhead Services

Overhead services must meet the minimum clearance above the finished grade or other accessible surface as shown below. Make sure the point of attachment is high enough to meet these requirements.

Contact Idaho Power for height requirements when the service wire must cross over areas that are not addressed here (such as a road, highway, railroad track, canal, waterway, etc.).

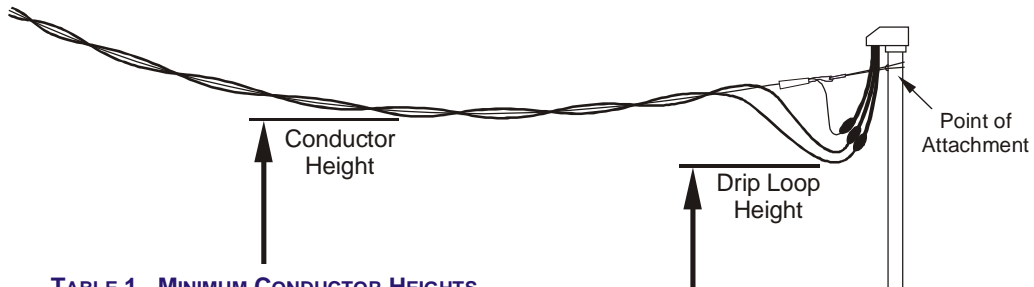

**TABLE 1. MINIMUM CONDUCTOR HEIGHTS**

Tx & Qx Conductors up to 750 Volts	
Pedestrian Areas (no vehicles, horses, or trampolines)	15'-0" min.
Residential Driveways	16'-0" min.
Areas with Truck Traffic (alleys, parking lots, etc.)	18'-6" min.

Use the heights shown in **Table 1** for **All** applications

**EXCEPTION:** Where the Building Limits the Drip Loop Height, use 10'-6" minimum for Tx & Qx Conductors in Pedestrian Only Areas (Up to 150V line-to-ground)

**NOTES.**

- Height over pedestrian areas can be reduced to 12'-0" for voltages up to 300V line-to-ground.
- Add 6" to all heights for open wire conductors.

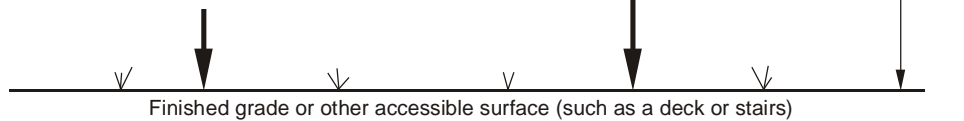

# Requirements for Single-Phase (1-Ø) Overhead Electric Service

## Services Over Building Roofs

A service conductor or the drip loop that crosses over the roof of the building that it serves must meet the minimum conductor height over the roof shown in Table 1 *Minimum Conductor Heights*.

There are three exceptions where reduced clearances are permitted:

**Exception 1.** A service conductor (or the drip loop) up to 600 volts line-to-line that crosses over a non-accessible roof must have a clearance of 8'-0" over the roof. A roof may be considered non-accessible if it is not accessible by a door, window, stairway, or fixed ladder.

**Exception 2.** A service conductor (or its drip loop) up to 300 volts line-to-line that crosses over a non-accessible roof with a slope of at least 4 to 12 must have a clearance of 3'-0" over the roof.

**Exception 3.** A Tx or Qx service conductor (or its drip loop) up to 300 volts line-to-line that crosses only the eave portion of the roof where it reaches the service mast must have an 18" clearance over the roof. The service mast must not be more than 4'-0" from the edge of the roof and only 6'-0" of the service conductor may be above the roof as shown.

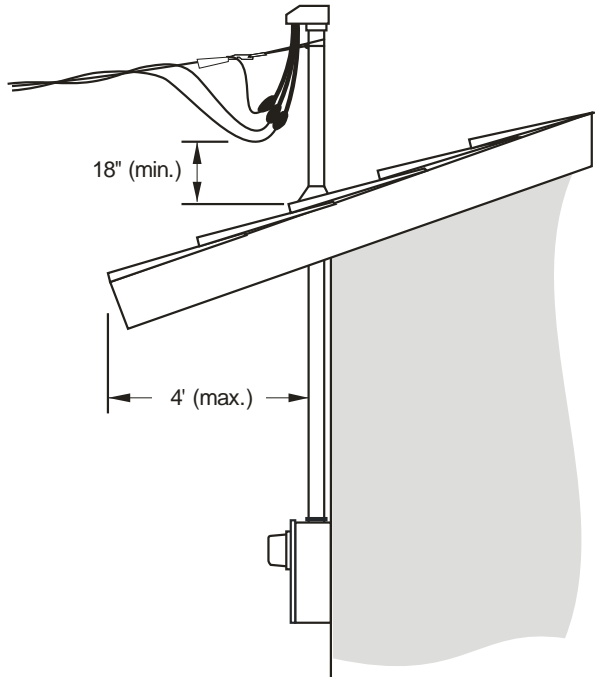
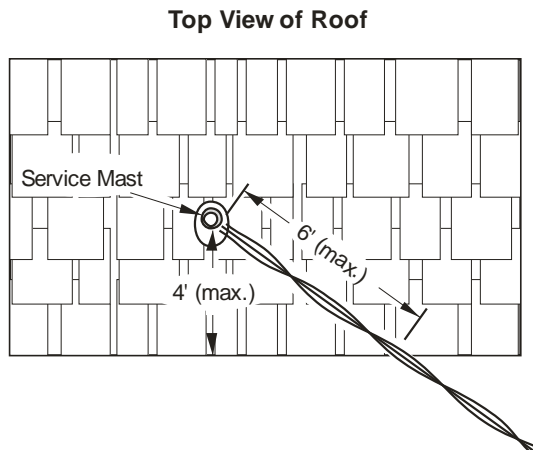

**Illustration of Exception 3**

# Requirements for Single-Phase (1-Ø) Overhead Electric Service

## 1-Ø Overhead Service to a Building

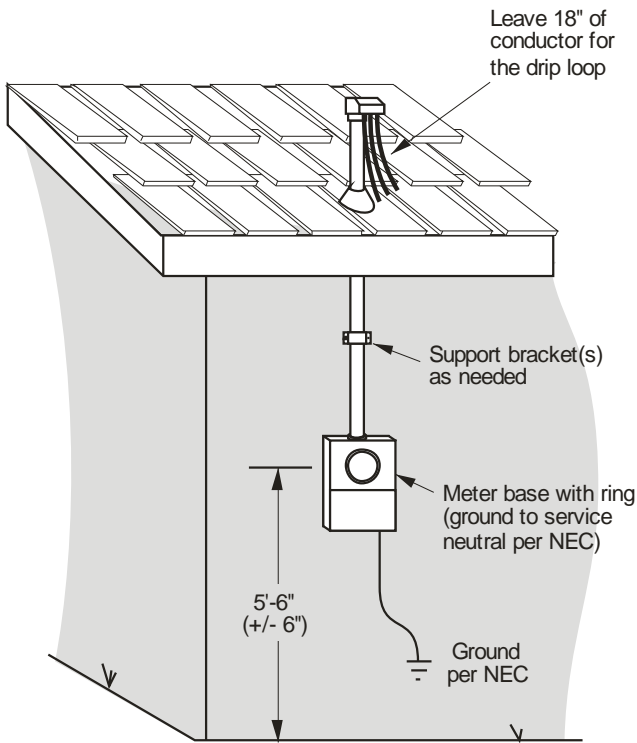

## 1-Ø Overhead Service to a Pole

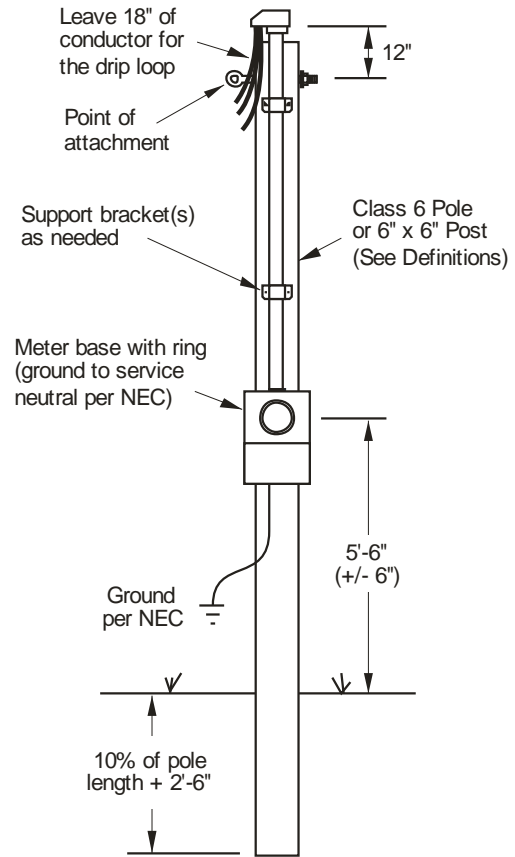

### Idaho Power Provides

Meter  
Service conductor  
Connections at the drip loop

### Customer Provides

Pole or building to attach the meter base  
Point of attachment  
Meter base  
Conductor from the meter base to the drip loop  
Ground electrode(s), ground wire and connections to ground the meter base per NEC

**NOTE.** The service mast must be adequately supported so that it does not bend, lean, or pull loose due to the tension of the service wire. Larger service wires or services in high snow areas may require additional support.

# Requirements for Single-Phase (1-Ø) Overhead Electric Service

## 1-Ø Overhead CT Service to a Building

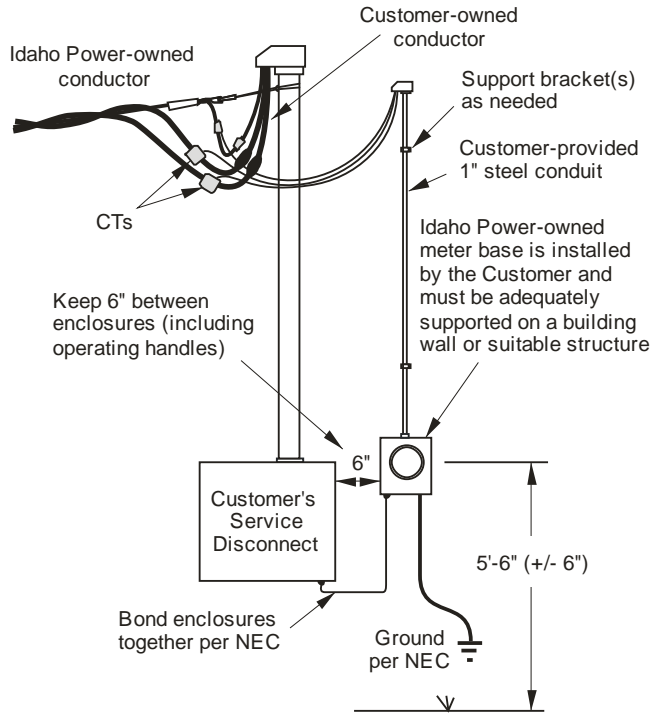

## 1-Ø Overhead CT Service to a Pole

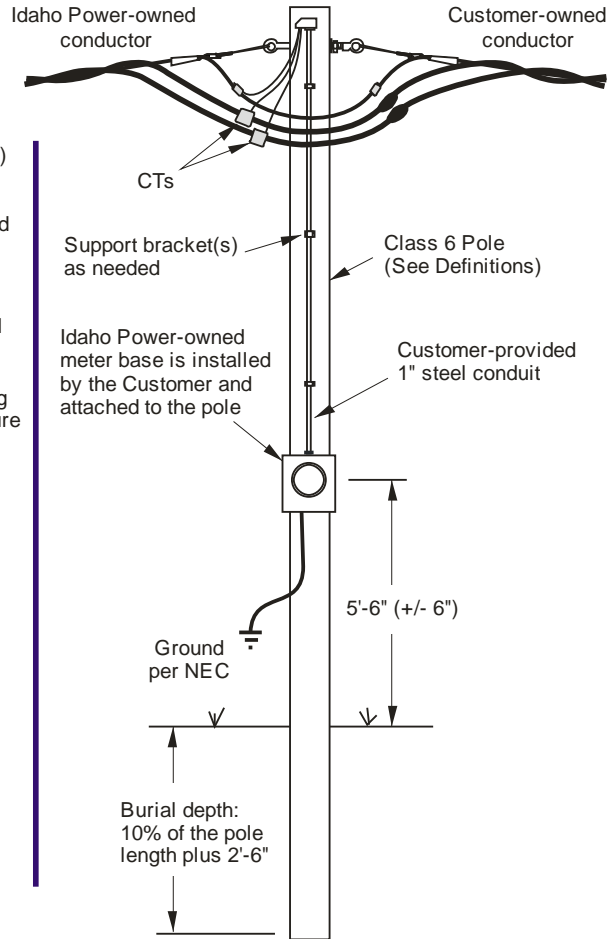

### Idaho Power Provides

Meter base  
Meter and CTs  
Metering wires  
Service conductor  
Connections at the drip loop

### Customer Provides

Pole, structure, or building to attach the meter base  
Point of attachment  
Installation of the meter base  
1" EMT conduit and entrance cap  
Conductor from the customer's service disconnect to the drip loop  
Ground electrode(s), ground wire and connections to ground the meter base per NEC

### NOTES.

- 1) The service mast must be adequately supported so that it does not bend, lean, or pull loose due to the tension of the service wire. Larger service wires or services in high snow areas may require additional support.
- 2) There is an additional charge for CT metering when the customer's main breaker or panel size is 400 amps or less.